

规格承认书

Specification for approval

产品名称: **BFMN 迷你插片汽车保险丝 32V**

Product Type: ISO8820-3 Standard BFMN-1225

Automotive Car ATM Mini Blade Fuse 25A 32V Natural

11mm For In-line Fuse Holder Adapter

Ao littel Technology Co.Ltd.

Bld. 16,Yanhe East Road,Xiangdong Village, Dongguan 523833,
Guangdong,China

H.P.: 1371362419

QQ #: 3217998702

<http://www.passivemall.com/>

Fax #:0769-89390418

Email : eric.lye@aolittel.com

<http://www.aolittel.com/>

1. Scope

BFMN is a lower-cost and more compact BFAT

2. General Specifications

Rated Voltage: DC32V and less

Breaking Capacity: 1000A

Operation Temperature: -40°C - 80°C

Standard: ISO8820-3

3. Time-Current Characteristics

% of Ampere Rating(A)	Operating Time	
	MIN	MAX
110%	100 hrs.	-
135%	0.75 sec.	600 (120) sec.
160%	0.25 sec.	50 sec.
200%	0.15 sec.	5 sec.
350%	0.04 sec.	0.5 sec.
600%	0.02 sec.	0.1 sec.

※The fuse characteristic may change depending on the conditions of use.

4. Electrical Performances

Ampere Rating(A)	Part Number	Housing Colors	Resistance Value	Voltage Drop
1A	1281	Black	121 mΩ	175 mV
2A	1202	Gray	49.7 mΩ	140 mV
3A	1203	Violet	29.6 mΩ	140 mV
4A	1204	Pink	23.8 mΩ	136 mV
5A	1205	Tan	16.7 mΩ	112 mV
7.5A	1207	Brown	11.1 mΩ	112 mV
10A	1210	Red	7.82 mΩ	106 mV
15A	1215	Blue	4.93 mΩ	99 mV
20A	1220	Yellow	3.48 mΩ	95 mV
25A	1225	White(natural)	2.58 mΩ	92 mV
30A	1230	Green	2.12 mΩ	86 mV

※The fuse characteristic may change depending on the conditions of use.

5. Dimension (mm)

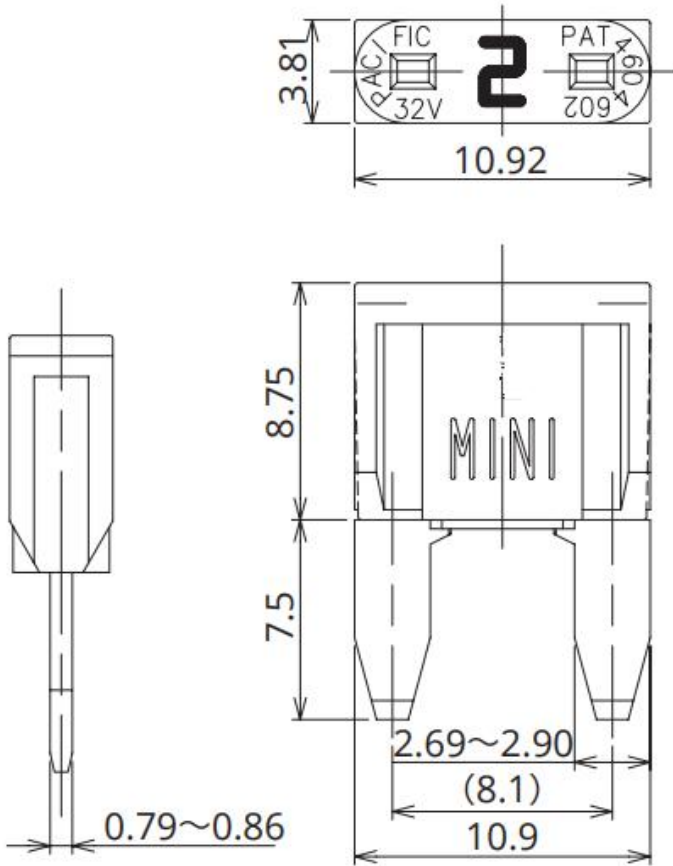

6. Time-Current Characteristics Chart

